

Products Catalogue

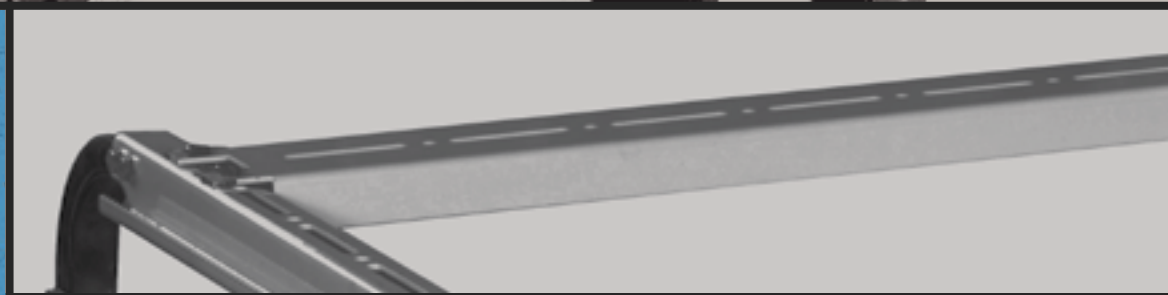

**APPLIANCES
FIXATION
SYSTEM**

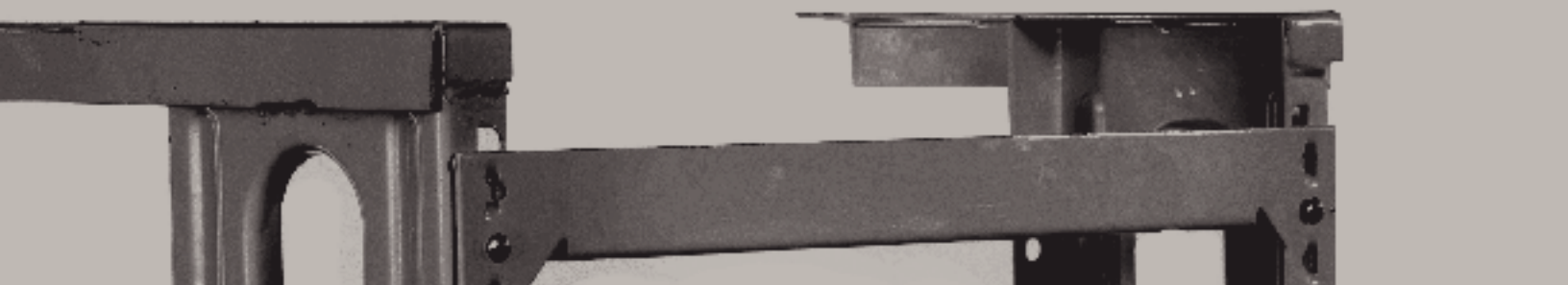

HARMONY[®]
SUPPLIER

QUALITY
EMPOWERS
YOU.

ABOUT HARMONY

0.1

Harmony Group is the national market leader in several sheet metal products and successfully develops new types of applications for sheet metal that can be used in various fields. The privately owned company based in Giza, Egypt, develops and manufactures high specialized products for different home appliances products.

The Factory is located in the 3rd industrial zone, 6th of October, Giza, Egypt. Harmony's facility covers a manufacturing area of 2000 m² where more than 250 hard working employee get the work done. Combining decades of technical experience with modern management. Harmony is constantly expanding its business.

CERTIFICATION

CERTIFICATES

ISO 9001:2015



ISO 14001:2015



Scan this QR Code with smartphone to verify the certificate

CERTIFICATE OF REGISTRATION



This is to certify that:

HARMONY
(ALAA OSAMA MAHMOUD AND HIS PARTNERS)

PLOT 230, THIRD INDUSTRIAL ZONE,
6TH OF OCTOBER, GIZA - EGYPT

Additional Site:
1, NEW MARWA BUILDING, AHMED TAYSEER STREET,
NASR CITY, EGYPT

the management system of the above organisation has been assessed and found to comply with the requirements of the management system standards detailed below

STANDARD

ISO 14001:2015

Environmental Management System

Certification Scope

Manufacturing of All Steel and Construction and Supports for Pipes and Process Components Products and Sheet Metal Fabrication.
Design, Supply, Installation, Testing, Commissioning & After Sales Service of All Types of HVAC (Heating, Ventilation and Air-Conditioning) Systems.
Design, Supply, Installation, Testing & Commissioning of All Types of Fire-Fighting Systems.

Certification Calendar

Certificate Number IAS2612144669	Date of Registration 26-Dec-2022	**Validity of this certificate is subject to successful and timely completion of the annual surveillance audit.
Client ID HA2086	Valid From 26-Dec-2022	Note¹: Certification cycle expiry date of this certificate is - 25-Dec-2025.
Revision No. 00	Valid Until 25-Dec-2023	Note²: Surveillance 01 will be due in the month of Nov-2023 and Surveillance 02 will be due in the month of Nov-2024.

**This certificate remains the property of SAGACI and shall have to be returned back when it has ceased to be valid, for whatever reason.
*Information about this certificate can be inquired at the official website of certification (www.sagaciert.com)



Authorized Signatory





ACCREDITED
Management System
Certification Body
ISO/IEC

SAGACI CERTIFICATIONS PRIVATE LIMITED
www.sagaciert.com

This certificate has been issued by Sagar Certifications Pvt. Ltd., B-1, 2, Block 10, Sector 10, Gurgaon, Haryana, India. It is valid only if the client complies with the requirements of the standard. This will be reviewed regularly by SAGACI. The use of ISO accreditation marks indicates accreditation in respect of those activities covered by the accreditation certificate. Further clarification regarding the scope of this certificate and verification of the certificate is available through SAGACI or www.sagaciert.com.
Phone: 011-43692111, Email: info@sagaciert.com, Web: www.sagaciert.com

ISO 45001:2018



Scan this QR Code with smartphone to verify the certificate

CERTIFICATE OF REGISTRATION



This is to certify that:

HARMONY
(ALAA OSAMA MAHMOUD AND HIS PARTNERS)

PLOT 230, THIRD INDUSTRIAL ZONE,
6TH OF OCTOBER, GIZA - EGYPT

Additional Site:
1, NEW MARWA BUILDING, AHMED TAYSEER STREET,
NASR CITY, EGYPT

the management system of the above organisation has been assessed and found to comply with the requirements of the management system standards detailed below

STANDARD

ISO 45001:2018

Occupational Health & Safety Management System

Certification Scope

Manufacturing of All Steel and Construction and Supports for Pipes and Process Components Products and Sheet Metal Fabrication.
Design, Supply, Installation, Testing, Commissioning & After Sales Service of All Types of HVAC (Heating, Ventilation and Air-Conditioning) Systems.
Design, Supply, Installation, Testing & Commissioning of All Types of Fire-Fighting Systems.

Certification Calendar

Certificate Number IAS2612454470	Date of Registration 26-Dec-2022	**Validity of this certificate is subject to successful and timely completion of the annual surveillance audit.
Client ID HA2086	Valid From 26-Dec-2022	Note¹: Certification cycle expiry date of this certificate is - 25-Dec-2025.
Revision No. 00	Valid Until 25-Dec-2023	Note²: Surveillance 01 will be due in the month of Nov-2023 and Surveillance 02 will be due in the month of Nov-2024.

**This certificate remains the property of SAGACI and shall have to be returned back when it has ceased to be valid, for whatever reason.
*Information about this certificate can be inquired at the official website of certification (www.sagaciert.com)



Authorized Signatory





ACCREDITED
Management System
Certification Body
ISO/IEC

SAGACI CERTIFICATIONS PRIVATE LIMITED
www.sagaciert.com

This certificate has been issued by Sagar Certifications Pvt. Ltd., B-1, 2, Block 10, Sector 10, Gurgaon, Haryana, India. It is valid only if the client complies with the requirements of the standard. This will be reviewed regularly by SAGACI. The use of ISO accreditation marks indicates accreditation in respect of those activities covered by the accreditation certificate. Further clarification regarding the scope of this certificate and verification of the certificate is available through SAGACI or www.sagaciert.com.
Phone: 011-43692111, Email: info@sagaciert.com, Web: www.sagaciert.com

Galvanization Methodology.

Hot-dip galvanizing is the process of immersing iron or steel in a bath of molten zinc to produce a corrosion resistant, multi-layered coating of zinc-iron alloy and zinc metal. While the steel is immersed in the zinc, a metallurgical reaction occurs between the iron in the steel and the molten zinc. This reaction is a diffusion process, so the coating forms perpendicular to all surfaces creating a uniform thickness throughout the part.

FIRST STEP

SURFACE PREPARATION

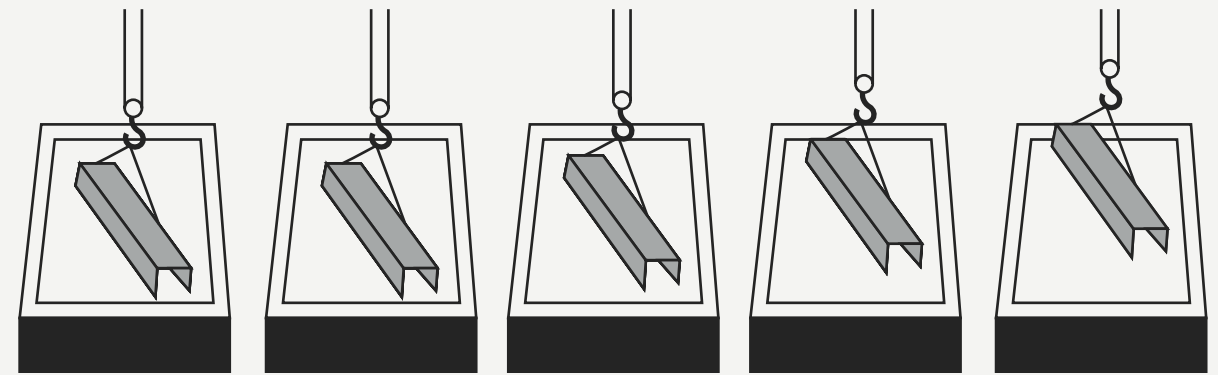

Caustic Cleaning

Rinsing

Pickling

Rinsing

Flux Solution

SECOND STEP

GALVANIZING Molten Zinc Bath

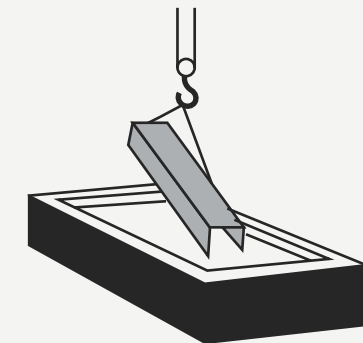

FINAL STEP

INSPECTION

Cooling and
Quality Assurance

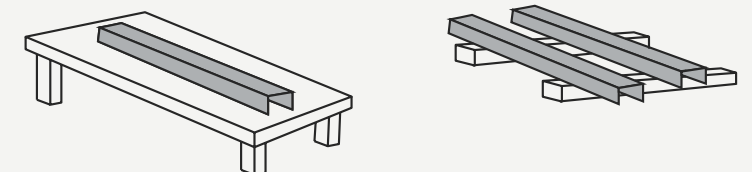

Maximum Allowed Load.

From most of our products a maximum allowed load is included in the article tables. Stand values are determined by the measuring method described in the testing prescriptions RAL-GZ 655, which is set up by the 'Gütegemeinschaft Rohrbefestigung!'. If the product is provided with the 'RAL-Gütezeichen', the test results are checked by an independent testing institute.

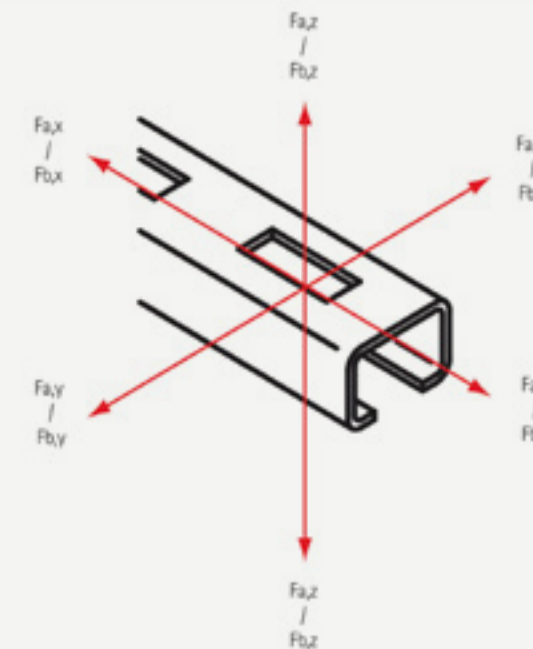
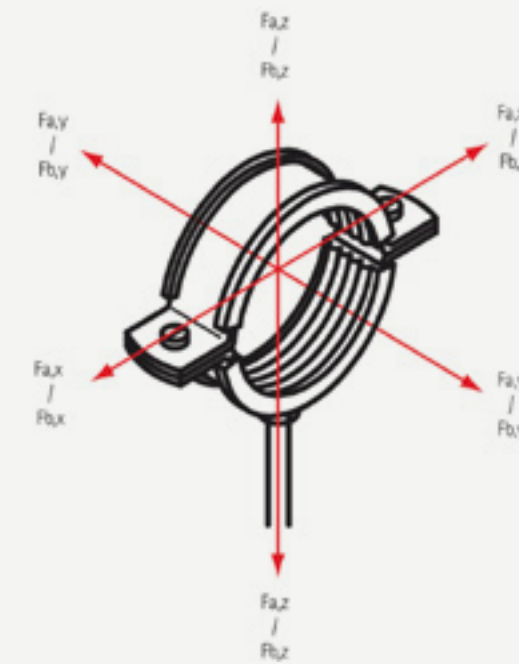

Force Directions (F) x, y, and z (at 20°C)

F_a = Maximum Allowe Load
 F_b = Breaking Load
 For plastic clamps the breaking load is included.

Commitment To Quality

Our commitment to quality is clearly revealed in the way we do our business; our processes, our close interaction with our clients as well By delivering superior products tailored to the specific construction needs, ambitious solutions, and an outstanding as the strict product inspection procedures.

To achieve this, we have implemented quality systems & processes that are continually being improved to satisfy our customer's needs

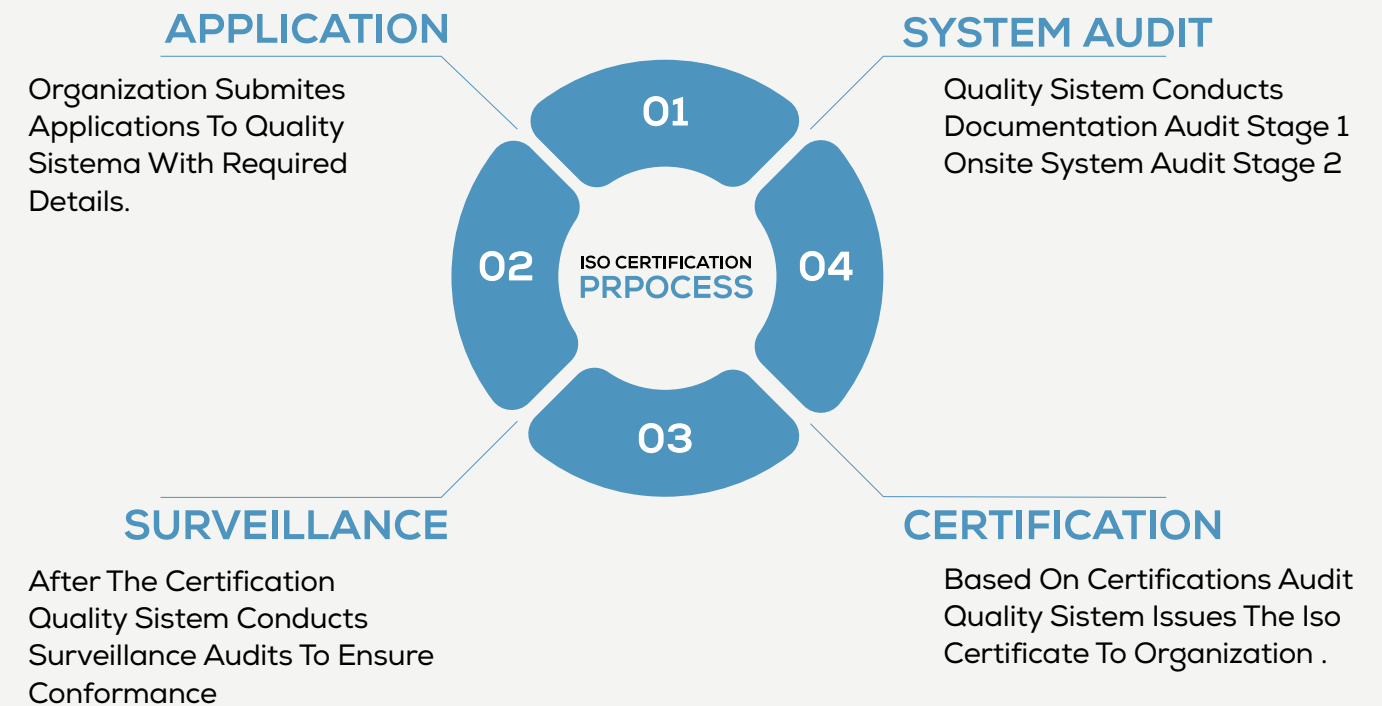

APPLIANCES FIXATION SYSTEM

1.0

APPLIANCES FIXATION SYSTEM

1.1

Air Conditioning Bracket

- 1.1.1 AC Bracket 1.5h-3hp
- 1.1.2 AC Bracket 4h-5hp

PAGE 19



1.2

Air Conditioning Cantilivers

- 1.2.1 Multi-Brand Size 1.5h-5hp

PAGE 23



1.3

Equipment & Appliances Base

- 1.3.1 Duckleg

PAGE 25



AC Bracket 1.5HP-3HP

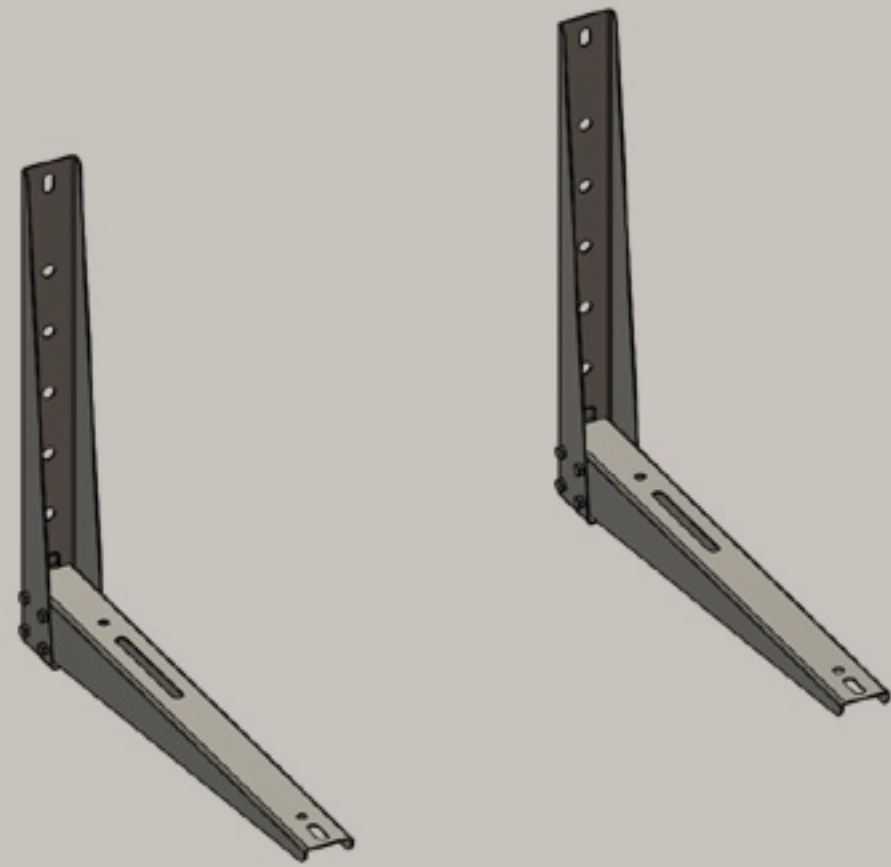

Part No.	Type	H (mm)	L (mm)	S (mm)
Cantliver-1 (KSA)	1.5:3 HP	550	500	2

FEATURES & BENEFITS

Heavy design - Material: steel

Designed for carry different types of AC Brands.

Load tested up to 300 KGs

With CO2 welded connection nut

Electrogalvanized as per ASTM B 633

Standards (SC3), BS 1706 FE/ZN 12

Designed to meet MSS Standard SP-

58-2002, type 43 and SP-69

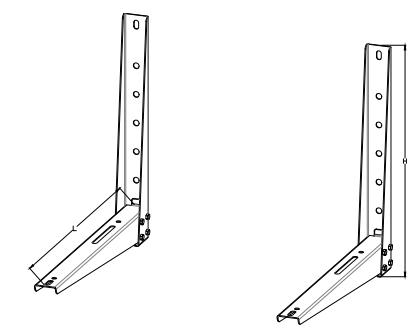

Hot Dip Galvanized, Stainless Steel, and Electrical Foption available on request.
 With connection nut M8/M10, M10/M12 available on request.
 With M6 Side Nuts available on request.

AC Bracket 4HP-5HP

Part No.	Type	H (mm)	B (mm)	L (mm)	S (mm)
Cantiliver-2 (KSA)	15:3 HP	500	260	600	2

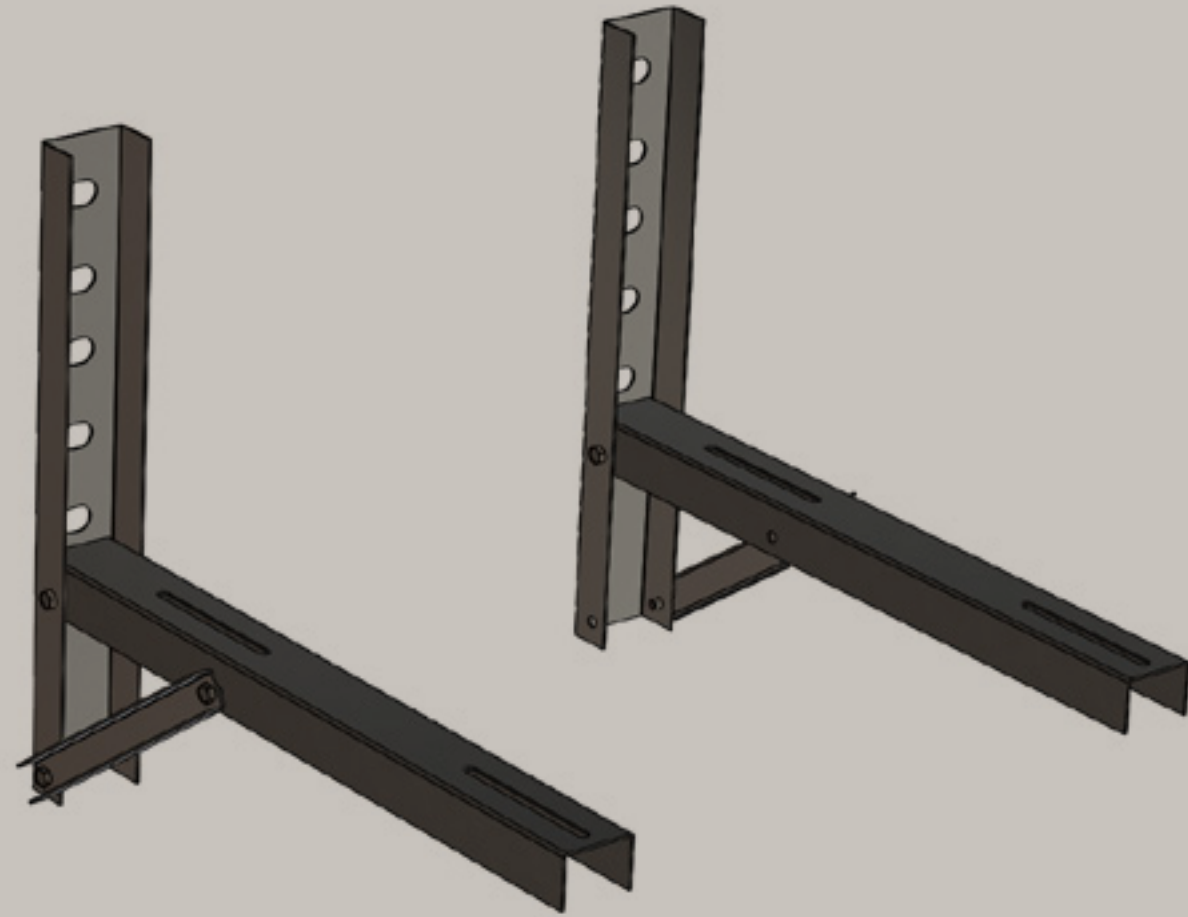

FEATURES & BENEFITS

Heavy design - Material: steel

Carry different types of AC Brands.

Load tested up to 300 KGs

With CO2 welded connection nut

Salt Spray tested

Electrogalvanized as per ASTM B 633

Standards (SC3), BS 1706 FE/ZN 12

Designed to meet MSS Standard SP-

58-2002, type 43 and SP-69

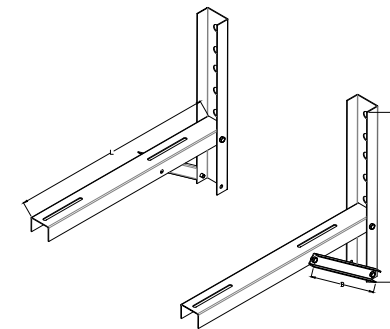

Hot Dip Galvanized, Stainless Steel, and Electrical Option available on request.
With connection nut M8/M10, M10/M12 available on request.
With M6 Side Nuts available on request.



Multi-Brand Size Cantilever 1.5HP-5HP

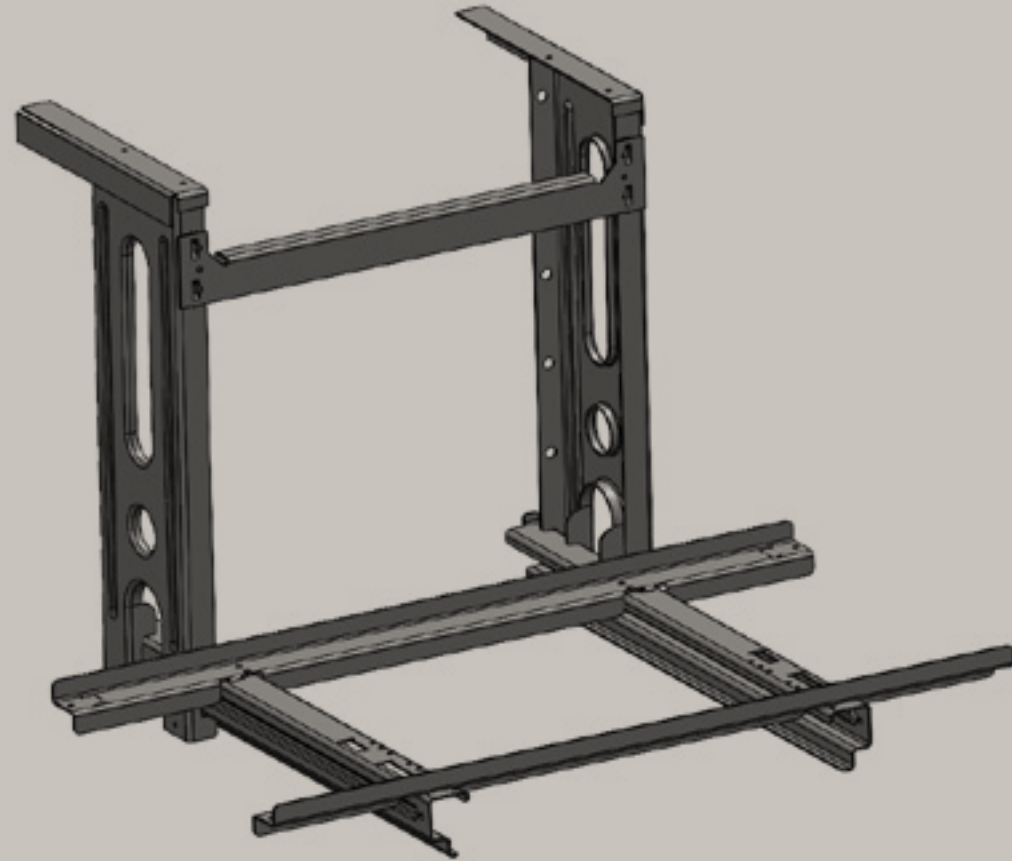

FEATURES & BENEFITS

This cantilever is designed to withstand the weight of 350 KGs

Load tested up to 300 KGs

With CO2 welded connection nut

Salt Spray tested

This cantilever is designed to suit air

conditioners capacities (12,000 BTU

to 24,000 BTU) for almost all brands

available in the Egyptain market.



Part No.	Type	H (mm)	B1 (mm)	B2 (mm)	B3 (mm)	L (mm)	S (mm)
Cantilever (RCC-2020)	12 BTU	410	330	330	455	390	15
Cantilever (RCC-2020)	12:18 BTU	490	330	725	455	550	18
Cantilever (RCC-2020)	18:24 BTU	490	820	820	550	650	2

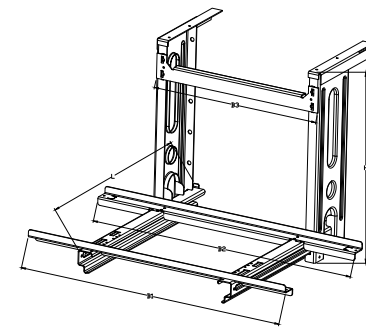

Hot Dip Galvanized, Stainless Steel, and Electrical Foption available on request.
With connection nut M8/M10, M10/M12 available on request.
With M6 Side Nuts available on request.



BIS Duckleg Frame Set & Extension



FEATURES & BENEFITS

Complete set for supporting installation appliances on flat roofs

Suitable for wide range of commonly used aircon's, ventilation units, etc.

With non-slip anti-vibration mat

Device can't be heavier than 1500 kg

predefined load capacity: calculation not necessary

Top of device can't be higher than 1.2 m over the roof level

Moldings made of WPC, a composite of recycled plastic and wood fiber



Part No.	Model	Pack1
6768 5 501	BIS Yeti 335 for 1 installation appliance	1
6768 5 502	BIS Yeti 335 for 2 installation appliances	1

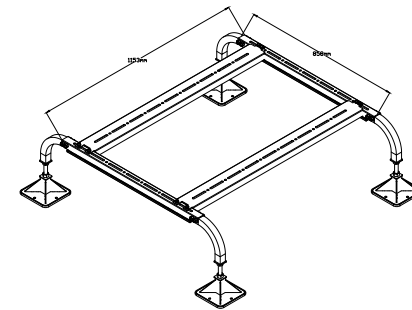
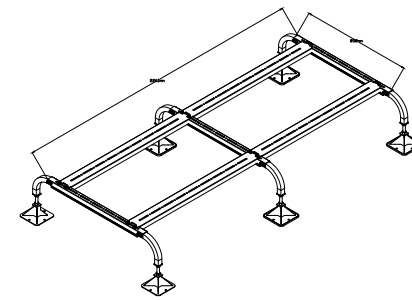

Hot Dip Galvanized, Stainless Steel, and Electrical Option available on request.
With connection nut M8/M10, M10/M12 available on request.
With M6 Side Nuts available on request.

OUR PRODUCTION ARM

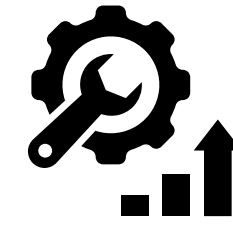

Leading
Manufacturer And
Fabricator



Region
Exposure

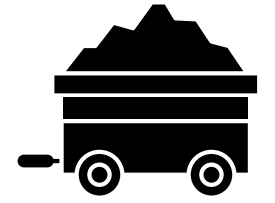

100%
Raw Material

0.5

Harmony Manufacturing is a leading manufacturer and fabricator of light steel construction products in the region, servicing the construction sector.

Products of Harmony Manufacturing are manufactured from quality raw material according to the relevant international standards to meet all kinds of construction projects requirements.



Health And Safty

The Factory Management regard the health and safety of the employees, clients and all others that may be affected by their operations to be of a major importance.

In support of this, the management promotes health and safety throughout the factory's operations and endeavor to engender a positive attitude in all employees towards the prevention of accidents and maintenance of healthy working arrangements.



The Factory satisfies the requirements of the Health, Safety and related legislation by setting out the responsibilities of all levels of staff and the arrangements for carrying out those responsibilities and in particular do what is reasonably practicable to:

1. Maintains safe & healthy working conditions.
2. Ensures that all facilities and equipment are safe and properly maintained.
3. Provides products that can be applied and used safely and without risk to health.
4. Provides and maintain working procedures, that are safe and without risk to health, throughout the its operations in respect of: The use, handling, storage, transports and disposal of materials and substances, The use of factory equipment , Potential emergency situations, including first aid & fire and escape of substances.
5. Ensure the competence of employees by keeping trained and up tp date with the latest in the industry both technically and in terms of safety.

Social Responsibility

Being socially responsible is a part of who we are and how we do our business. We aim to provide useful products and services, to provide jobs and development opportunities for our communities, and satisfaction through meaningful work.

We make a difference by acting on the values and principles of our societies and we inspire others to do at Harmony, we anticipate and reduce threats caused by environmental changes or natural disasters, and we are well adapted to significant social changes. We contribute to a more sustainable society by means of value and support to our consumers & our supply chains.



WE ARE KEEN TO IDENTIFY WAYS THEY CAN IMPROVE OUR IMPACTS ON THE PEOPLE AND PLACES WE WORK.

- Organizational governance: We promote accountability and transparency at all levels.
- Human care: We treat individuals with respect; and make efforts to help members of vulnerable groups.
- Labor practices: We provide just, safe and favorable conditions to workers
- Environment: At Harmony, we identify and improve environmental impacts of our operations, including the resource use of natural resources and waste disposal.

At Harmony, we are committed to continuous improvement ongoing learning, process review and innovative thinking that foster new initiatives; and better practices.

Our environmental programs evolve to meet today's changing needs while protecting resources for future generations.

CONTACT INFORMATION

www.harmony-egy.com
info@harmony-egy.com

Plot 230, Third Industrial Zone, 6th of October, Giza, Egypt
المنطقة الصناعية الثالثة، القطعة ٢٣٠، مدينة 6 أكتوبر، الجيزة، مصر

+2 0111 521 3111
+2 0121 0 11 2633